

## SPECIAL SERIES CHAINS

## DE-BROUWER CHAIN

### DB 635 / 1524 PLAIN BLOCK LINK

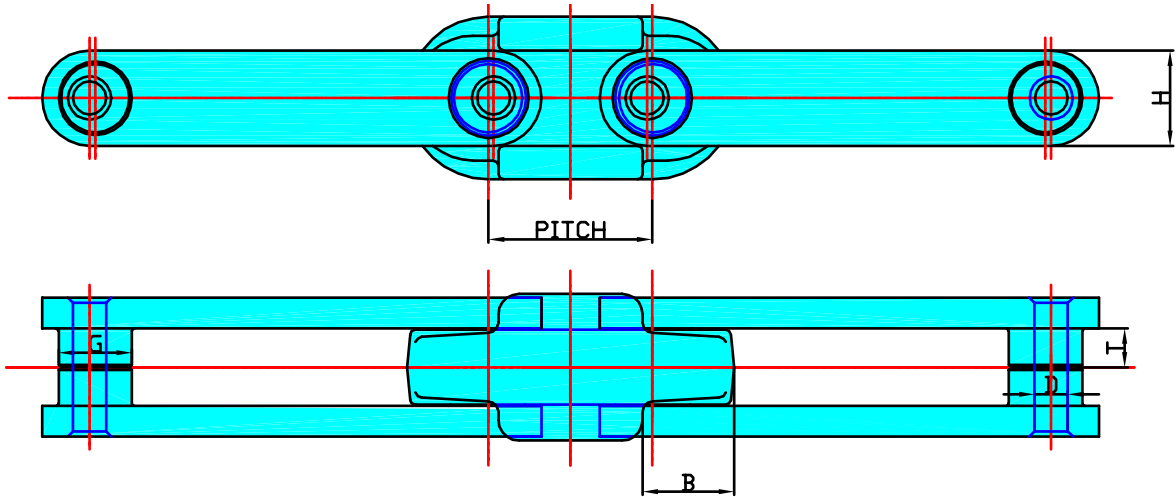

## STANDARD WEAR PAD

## EXTRA WIDE WEAR PAD

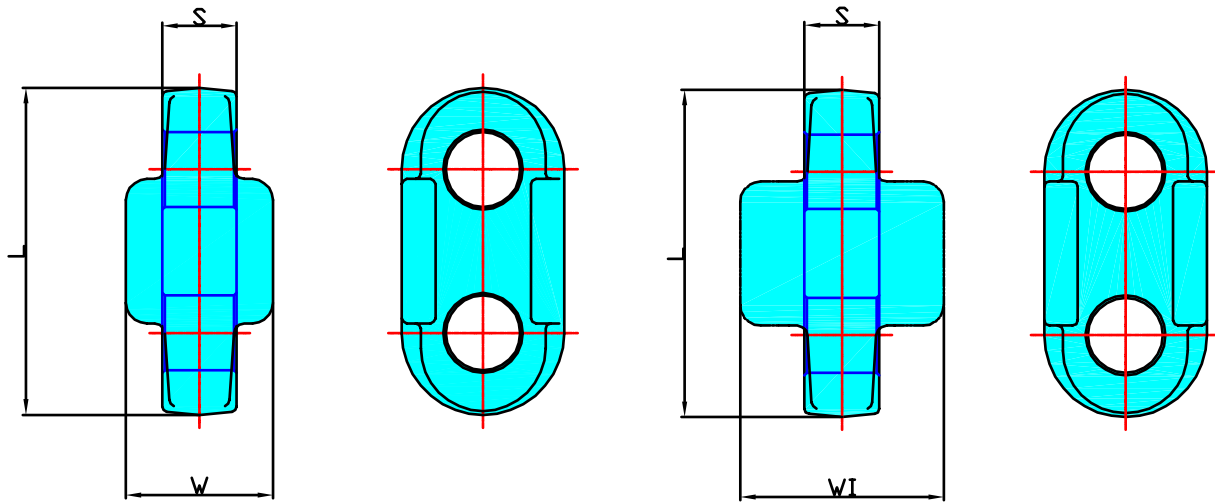

CHAIN N°	PITCH		D		L		W		WI*		H		B		G		T		S		CHAIN WEIGHT PER LINK kg
	in	mm	in	mm	in	mm	in	mm	in	mm	in	mm	in	mm	in	mm	in	mm	in	mm	
DB635/1524	2.5	63.5	0.61	13	5	127	2.24	57	3.11	79	1.47	37	1.40	35.5	1.12	28.5	0.59	15	1.14	29	1.4

WI\* Width of link with extra wide wear pads



(UK) John King Chains Limited.  
 New Climax Works, Lancaster Way, Sherburn in Elmet LS25 6NS UK  
 Telephone: (44) 01977 681910 Facsimile: (44) 01977 681899  
 E-mail: [admin@johnking-chain.com](mailto:admin@johnking-chain.com)  
[technical@johnking-chain.com](mailto:technical@johnking-chain.com)  
[sales@johnking-chain.com](mailto:sales@johnking-chain.com)

John King (USA) Inc.  
 200 Catherine Street, Unit 7B, E. Peoria IL61611 USA  
 Telephone: 309-698-9250 Facsimile: 309-698-9259  
 E-mail: [salesusa@johnking-chain.com](mailto:salesusa@johnking-chain.com)

Web: [www.johnkingchains.com](http://www.johnkingchains.com)