

## CONVEYOR CHAINS

## FV SERIES DIN 8165 SOLID PIN CHAIN

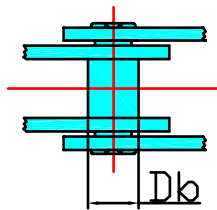

**TYPE "A"  
BUSH CHAIN**

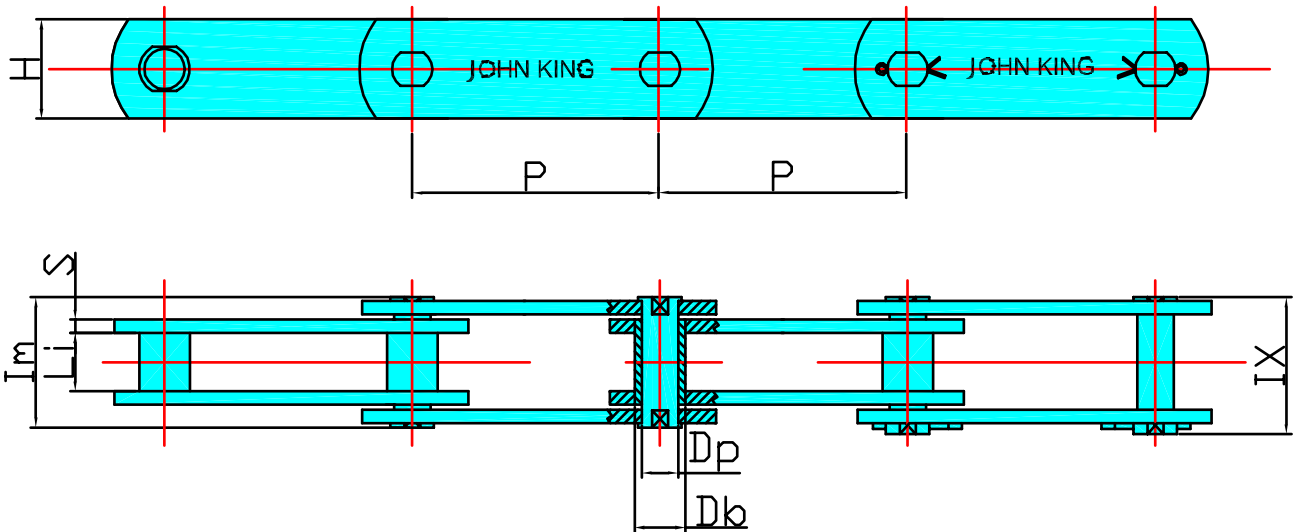
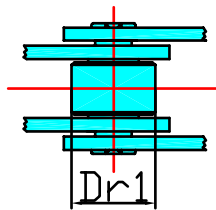

**TYPE "B"  
SMALL ROLLER**

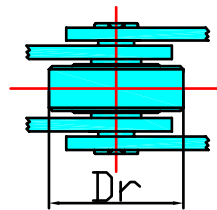

**TYPE "C"  
LARGE ROLLER**

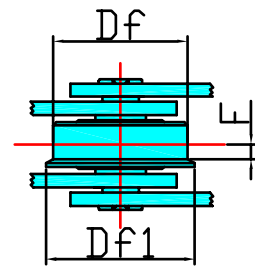

**TYPE "D"  
FLANGED ROLLER**

DIN N°	P mm	Li mm	Dr1 mm	Dr mm	Df mm	Df1 mm	F mm	Db mm	Dp mm	Hp mm	S mm	Im mm	IX mm	BREAKING LOAD	
														N	N *
FV 112	100	30	32	55	72	90	7.5	22	16	40	6	62	66	120.000	170.000
FV 112	125	30	32	55	72	90	7.5	22	16	40	6	62	66	120.000	170.000
FV 112	160	30	32	55	72	90	7.5	22	16	40	6	62	66	120.000	170.000
FV 112	200	30	32	55	72	90	7.5	22	16	40	6	62	66	120.000	170.000
FV 112	250	30	32	55	72	90	7.5	22	16	40	6	62	66	120.000	170.000
FV 140	100	35	36	60	80	100	9	26	18	45	6	67	71.5	145.000	180.000
FV 140	125	35	36	60	80	100	9	26	18	45	6	67	71.5	145.000	180.000
FV 140	160	35	36	60	80	100	9	26	18	45	6	67	71.5	145.000	180.000
FV 140	200	35	36	60	80	100	9	26	18	45	6	67	71.5	145.000	180.000
FV 140	250	35	36	60	80	100	9	26	18	45	6	67	71.5	145.000	180.000
FV 180	125	45	42	70	100	125	13	30	20	50	8	86	92	190.000	250.000
FV 180	160	45	42	70	100	125	13	30	20	50	8	86	92	190.000	250.000
FV 180	200	45	42	70	100	125	13	30	20	50	8	86	92	190.000	250.000
FV 180	250	45	42	70	100	125	13	30	20	50	8	86	92	190.000	250.000
FV 180	315	45	42	70	100	125	13	30	20	50	8	86	92	190.000	250.000
FV 250	160	55	50	80	125	155	15	36	26	60	8	97	103.5	275.000	300.000
FV 250	200	55	50	80	125	155	15	36	26	60	8	97	103.5	275.000	300.000
FV 250	250	55	50	80	125	155	15	36	26	60	8	97	103.5	275.000	300.000
FV 250	315	55	50	80	125	155	15	36	26	60	8	97	103.5	275.000	300.000



(UK) John King Chains Limited.  
New Climax Works, Lancaster Way, Sherburn in Elmet LS25 6NS UK  
Telephone: (44) 01977 681910 Facsimile: (44) 01977 681899  
E-mail: [admin@johnking-chain.com](mailto:admin@johnking-chain.com)  
[technical@johnking-chain.com](mailto:technical@johnking-chain.com)  
[sales@johnking-chain.com](mailto:sales@johnking-chain.com)

John King (USA) Inc.  
200 Catherine Street, Unit 7B, E. Peoria IL61611 USA  
Telephone: 309-698-9250 Facsimile: 309-698-9259  
E-mail: [salesusa@johnking-chain.com](mailto:salesusa@johnking-chain.com)

Web: [www.johnkingchains.com](http://www.johnkingchains.com)