

MILL CHAINS

AMERICAN PATTERN H CLASS

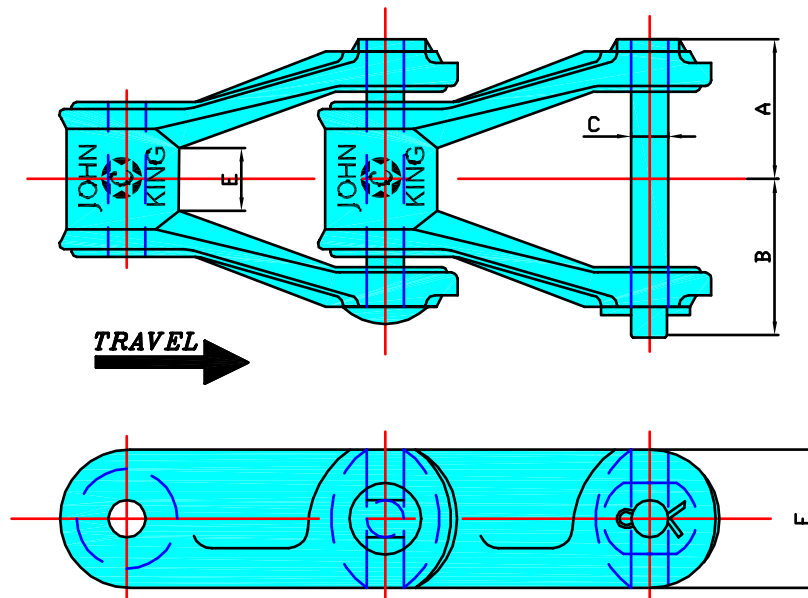

| CHAIN N° | APPROX PITCH | A | B | C | E | F | No OF LINKS IN 10 ft | ULTIMATE STRENGTH | NET WEIGHT |
|-------------|-----------------|--------------------------------|---------------------------------|--------------------------------|-------------------------------|--------------------------------|----------------------------|----------------------|---------------|
| | | | | | | | | lb | lb/ft |
| H.60 | 2.308 | 1 ⁵ / ₁₆ | 1 ¹ / ₂ | 5 ¹ / ₁₆ | 3 ³ / ₄ | 3 ³ / ₄ | 52 | 7000 | 2.1 |
| H.74 | 2.609 | 1 ⁷ / ₁₆ | 1 ⁹ / ₁₆ | 3 ³ / ₈ | 1 | 1 | 46 | 10000 | 3.0 |
| H.78 | 2.609 | 1 ⁵ / ₈ | 1 ³ / ₄ | 1 ¹ / ₂ | 1 ¹ / ₈ | 1 ¹ / ₈ | 46 | 16000 | 4.2 |
| H.82 | 3.075 | 2 | 2 ¹ / ₁₆ | 9 ¹ / ₁₆ | 1 ¹ / ₄ | 1 ¹ / ₄ | 39 | 20000 | 5.5 |
| H.124 | 4.000 | 2 ⁷ / ₁₆ | 2 ¹¹ / ₁₆ | 3 ³ / ₄ | 1 ⁵ / ₈ | 1 ⁹ / ₁₆ | 30 | 30000 | 8.8 |

