

ACETAL CASE CHAINS

PM600 / PM600D

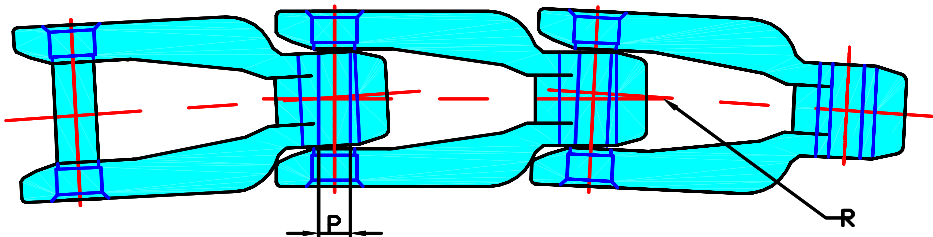
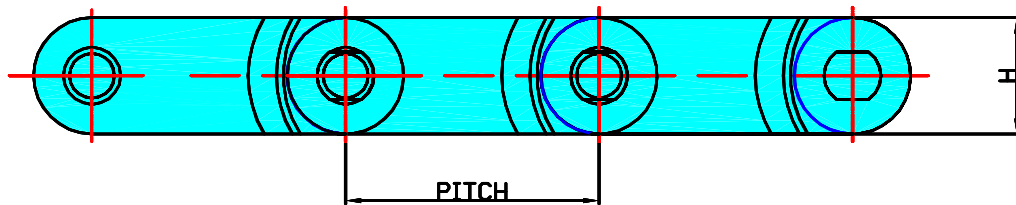

STANDARD TYPE

D TYPE

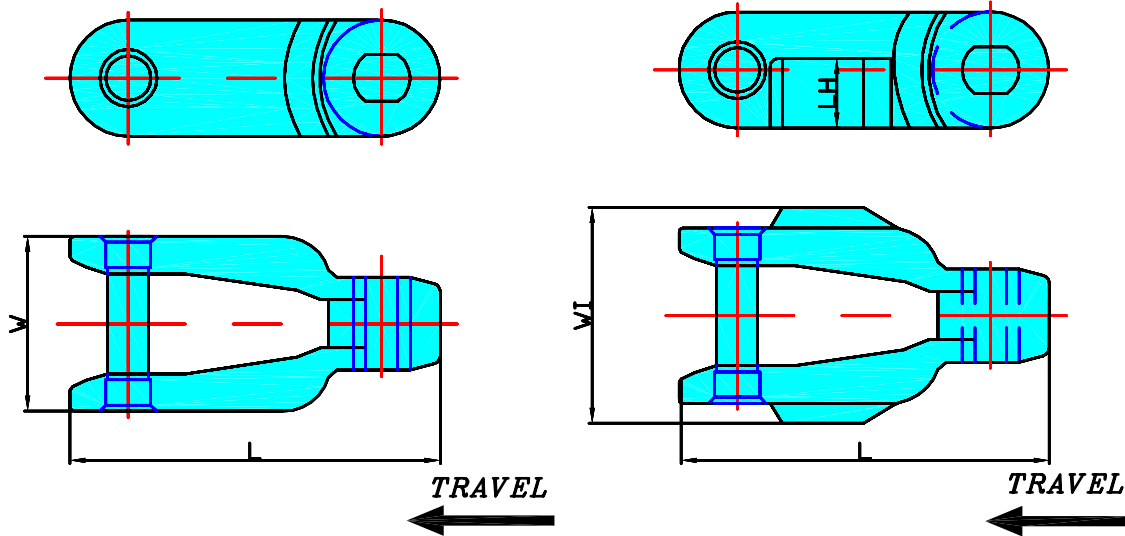

CHAIN N°	PITCH		P		PIN TYPE	L		W		WI		H		LH		R	CHAIN wt/m	UTS	MAX LOAD	
	in	mm	in	mm		in	mm	in	mm	in	mm	in	mm	in	mm					in
PM600	2.5	63.5	0.44	11	S,C,R	3.55	90.20	1.69	42.90	-	-	1.12	28.45	-	-	30	762	1.37	1540	840
PM600D	2.5	63.5	0.44	11	S,C,R	3.55	90.20	1.69	42.90	2.12	53.85	1.12	28.45	48	17.02	30	762	1.44	1540	840

Pin types: S- Snap in, C-Circlip, R-Rivet



(UK) John King Chains Limited.
 New Climax Works, Lancaster Way, Sherburn in Elmet LS25 6NS UK
 Telephone: (44) 01977 681910 Facsimile: (44) 01977 681899
 E-mail: admin@johnking-chain.com
 technical@johnking-chain.com
 sales@johnking-chain.com

John King (USA) Inc.
 200 Catherine Street, Unit 7B, E. Peoria IL61611 USA
 Telephone: 309-698-9250 Facsimile: 309-698-9259
 E-mail: salesusa@johnking-chain.com

Web: www.johnkingchains.com